

DWG No.013858201 MODEL : KTH-100X FORM : KTH-100X-BAR-0 (GX340UT2)

No.	PARTS CODE	PARTS NAME	QTY	MATERIAL/SIZE	REMARKS
1	0116150	PUMP CASING	1	ADC	
2	0118079	25A PLUG SET	2		
3	0115580	COVER BOLT	4	S35C	
4	0115678	MECHANICAL SEAL	1		
5	0116172	CUSHION RUBBER	6	CR	
6	0116273	RUBBER MOUNT	2	SPC T4.5	
7	846211012	WASHER	2		
8	827419012	NUT	2	SWRM M12	
9	0116492	FLANGE SOCKET BOLT	4	SCM M8×50	
10	0116493	WASHER	4		
11	0123207	HEAD PACKING	1	NBR	
12	0116148	DELIVERY HOUSING	1	ADC	
13	0110750	FLANGE PACKING	1	CR	
14	0118450	32A PLUG SET	1		
15	0111365	SUCTION FLANGE(NPT)	1	ADC	
16	0115590	KNOB	4		
17	0123208	FRONT COVER PACKING	1	NBR	
18	0115626	IMPELLER	1	HRFC	
19	0116490	FRONT COVER	1	ADC	
20	0116488	VOLUTE CASING	1	FCD450	
21	0121539	SOCKET BOLT	3	M8×35	
22	0121540	WASHER	3	8.1×17×T2	
23	0111579	SUCTION FLANGE(NPT)	1	ADC	
24	0118261	CHECK VALVE SET	1		
25	0123209	O-RING	1	NBR	
26	0127188	BASE SET	1		
27	842319008	SPRING NUT	6	SWRM	
28	743119083	BOLT	2	SWRM M12×45	
29	743119084	BOLT	2	SWRM M12×50	
30	743119076	BOLT	2	SWRM M12×25	

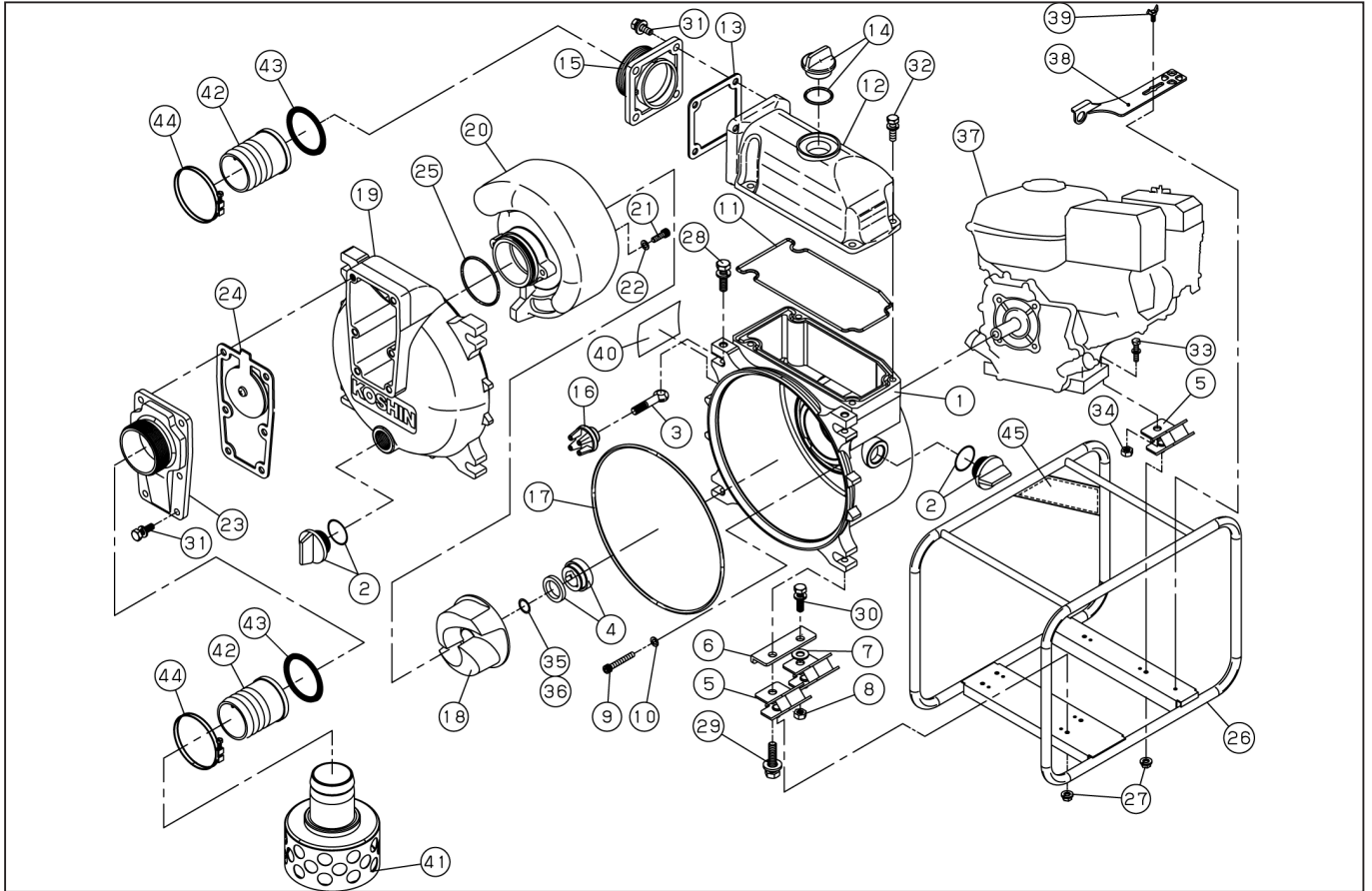

DWG No.013858201 MODEL : KTH-100X FORM : KTH-100X-BAR-0 (GX340UT2)

No.	PARTS CODE	PARTS NAME	QTY	MATERIAL/SIZE	REMARKS
31	743119080	BOLT	10	SWRM M12×35	
32	743119063	BOLT	4	SWRM M10×30	
33	743119067	BOLT	2	SWRM M10×40	
34	827419010	NUT	2	SWRM M10	
35	0110561	ADJUSTING WASHER	1	BSP	
36	0116405	ADJUSTING WASHER	2	BSP	
37	-	ENGINE(WITH ALART)	1	HONDA GX340UT2PKX2	
38	0116204	TOOL	1	SPC	
39	741305153	WING BOLT	1	SUS M8×15	
40	0123670	NAME PLATE	1		
41	0110979	STRAINER	1	SPC	
42	0110471	NIPPLE	2	ADC	
43	0111478	COUPLING PACKING	2	NBR	
44	940407120	HOSE BAND	3	4"	
45	0122307	SIDE PANEL LABEL	1		

◆ Bare engine can not be supplied