

DWG No.013863601 MODEL : SEH-50X FORM : SEH-50X-BGL-0 (GX160UH2)

No.	PARTS CODE	PARTS NAME	QTY	MATERIAL/SIZE	REMARKS
1	0120195	PUMP CASE	1	ADC	
2	0112662	SUCTION FLANGE	1	ADC	
3	0112665	CHECK VALVE	1	NBR	
4	0118078	20A PLUG SET	2		
5	0121226	FLANGE BRACKET	1	ADC	
6	0120933	VOLUTE CASING	1	FC	
7	0121227	IMPELLER	1	FC	
8	0110556	DELIVERY FLANGE	1	ADC	
9	0123234	FLANGE PACKING	1	NBR	
10	0128245	BASE SET	1		
11	0110491	IMPELLER ADJUSTING WASHER	3	CP2801P T0.3	
12	-	ENGINE	1	HONDA GX160	
13	0110664	MECHANICAL SEAL	1	φ 2 0	
14	0127122	COUPLING SET	2		
15	0122496	COUPLING	2	ABS	
16	0122497	NIPPLE	2	ABS	
17	0113391	COUPLING PACKING	2	NBR	
18	0127123	STRAINER SET	1	PP	
19	940019060	HOSE BAND	3	φ 60	
20	0123785	NAME PLATE	1		
21	0123213	O-RING	1	NBR 1517-42.5	
22	0112792	O-RING	1	NBR P54	
23	743119045	BOLT	3	SWRM M8 × 20	
24	743119047	BOLT	4	SWRM M8 × 25	
25	743119053	BOLT	4	SWRM M8 × 40	
26	743119046	BOLT	4	SWRM M8 × 22	
27	827419008	NUT	8	SWRM M8	
28	734532076	SOCKET BOLT	4	SCM CS M8 × 60	
29	854255008	SEAL WASHER	4	φ 8	
30	0117345	CUSHION RUBBER SET	1		

◆ Bare engine can not be supplied

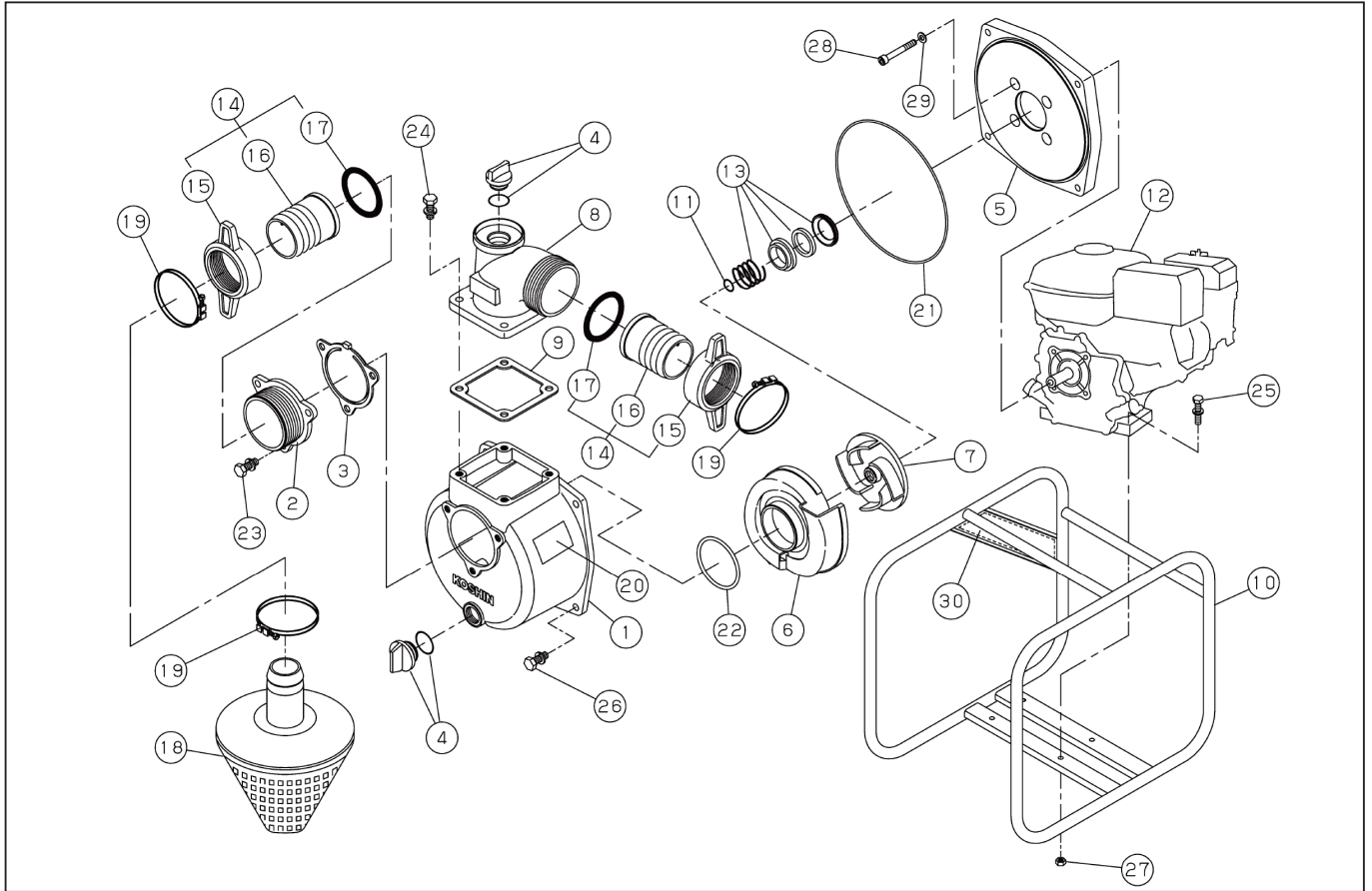

DWG No.013863601 MODEL : SEH-50X FORM : SEH-50X-BGL-0 (GX160UH2)

No.	PARTS CODE	PARTS NAME	QTY	MATERIAL/SIZE	REMARKS
31	0110515	CUSHION RUBBER	4	EPDM	
32	846007008	WASHER	4	φ 8	
33	843822008	SPRING WASHER	4	φ 8	
34	735719148	BOLT	4	M8 × 20	
35	0122307	SIDE PANEL LABEL	1		

◆ Bare engine can not be supplied