

DWG No.012903904 MODELE:STH-100X FORM:STH-100X-BAA-1

No.	PARTS CODE	PARTS NAME	QTY	MATERIAL/SIZE	LIST PRICE	REMARKS
1	0115691	PUMP CASING	1	ADC	16,500	
2	0116188	SUCTION FLANGE	1		5,350	
3	0117363	CHECK VALVE ASSY	1		1,300	
4	0118079	25A PLUG SET	2		300	
5	0115763	FLANGE BRACKET	1	ADC	8,400	
6	0120600	VOLUTE CASING	1	FCD450	7,300	
7	0120599	IMPELLER	1	FCD450	15,700	
8	0116187	DELIVERY FLANGE	1	ADC	5,100	
9	0110750	DELIVERY FLANGE PACKING	1	CR	800	
10	0110081	IMPELLER ADJUSTING WASHER	3	T0.3	100	
11	0115738	ENGINE (WITH ALERT)	1	HONDA GX240UT2WKK2	-	
12	0115678	MECHANICAL SEAL	1	HJ-25(B)BSIC	11,900	
13	0120943	NAME PLATE	1		100	
14	890455080	O-RING	1	1516-80 NBR	1,400	
15	889855090	O-RING	1	P90 NBR	300	
16	743119080	HEXAGON BOLT	8	M12X35 SWRM	150	
17	743119067	HEXAGON BOLT	4	M10X40 SWRM	100	
18	743119043	HEXAGON BOLT	1	M8X16 SWRM	100	
19	734532078	HEXAGON SOCKET BOLT(WITH WASHER)	4	M8X70 SCM CS	100	
20	827419010	HEXAGON NUT	4	M10 SWRM	100	
21	854255008	SEAL WASHER	4	φ 8	100	
22	0128185	BASE SET	1		21,300	
23	0115923	RUBBER MOUNT	1	26X12X5	250	
24	0120601	LONG BOLT	4		2,200	
25	0120602	SPANNER HOLDER	1	SPCC T=2.0	750	
26	0117639	COUPLING SET	2		10,550	
27	0116189	COUPLING	2	ADC	3,700	
28	0110471	HOSE NIPPLE	2	ADC	6,200	
29	0111478	COUPLING PACKING	2	NBR	650	
30	940019120	HOSE BAND	3	φ 120	400	

◆ Bare engine can not be supplied

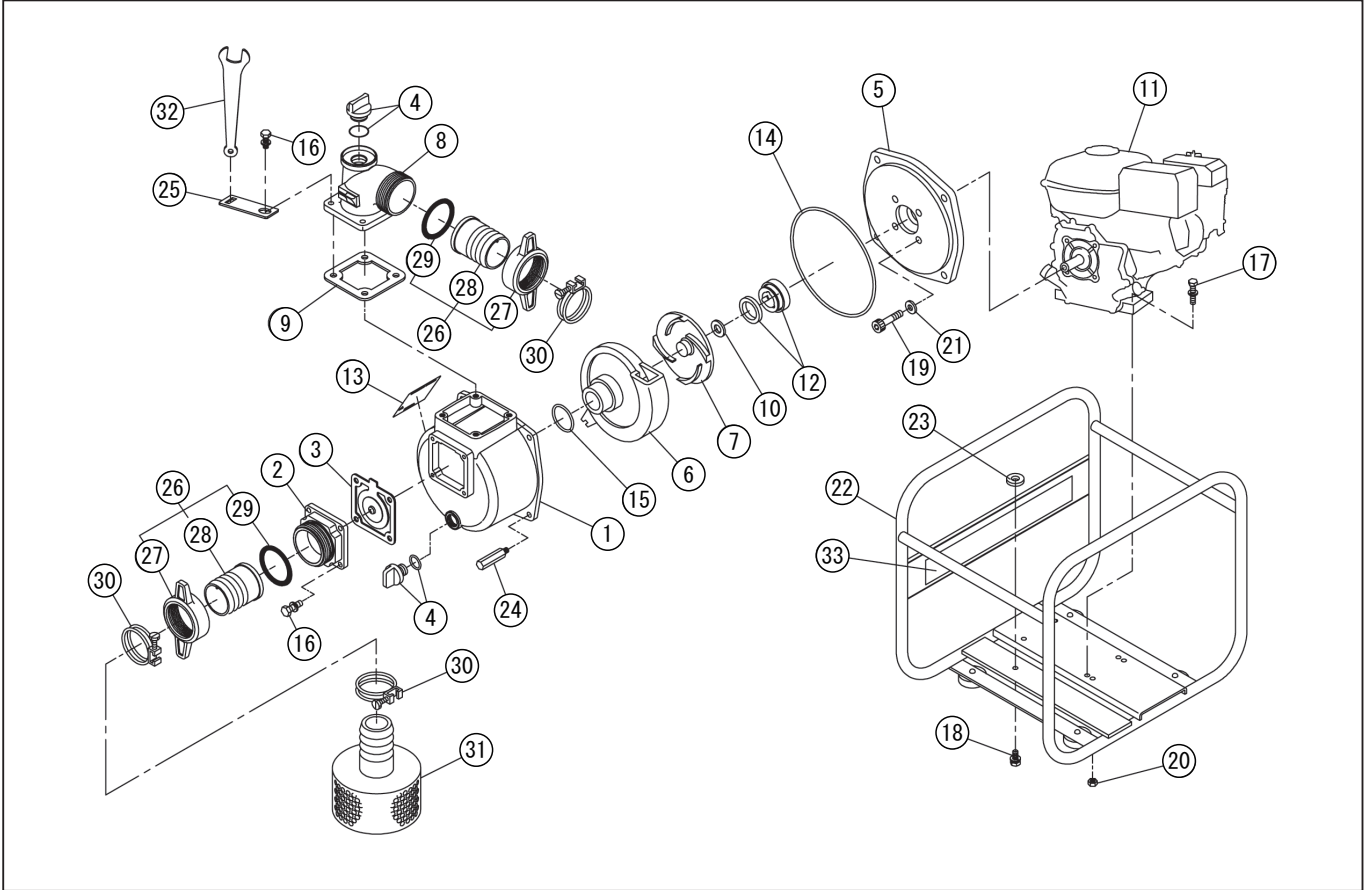

DWG No.012903904 MODELE:STH-100X FORM:STH-100X-BAA-1

No.	PARTS CODE	PARTS NAME	QTY	MATERIAL/SIZE	LIST PRICE	REMARKS
31	0111217	STRAINER	1	SPC	7,700	
32	0120603	SPANNER	1		1,200	
33	0120428	SIDE PANEL LABEL	1		200	
	0120944	PACKING CASE	1		3,200	

◆ Bare engine can not be supplied