

DWG No.066869602 MODELE:STH-50X FORM:STH-50X-BFH-0

No.	PARTS CODE	PARTS NAME	QTY	MATERIAL/SIZE	REMARKS
1	0121335	PUMP CASE	1		
2	0112662	SUCTION FLANGE	1		
3	0112665	CHECK VALVE	1		
4	0118078	20A PLUG SET	2		
5	0115268	FLANGE BRACKET	1		
6	0115169	VOLUTE CASING	1		
7	0120144	IMPELLER	1		
8	0110556	DELIVERY FLANGE	1		
9	0110541	FLANGE PACKING	1		
10	0127179	BASE SET	1		
11	0122307	SIDE PANEL LABEL	1		
12	0110466	ADJUSTING WASHER	3		
13	-	ENGINE	1		
14	0115159	MECHANICAL SEAL	1		
15	0117026	COUPLING SET	2		
16	0113390	COUPLING	4		
17	0110356	HOSE NIPPLE	4		
18	0113391	COUPLING PACKING	4		
19	0111286	STRAINER	1		
20	940019060	HOSE BAND ϕ 60	3		
21	0123090	NAME PLATE	1		
22	0115014	O-RING 1517-42.5	1		
23	0112792	O-RING P54	1		
24	743119045	BOLT M8 \times 20	3		
25	743119047	BOLT M8 \times 25	4		
26	743119051	BOLT M8 \times 35	4		
27	827419008	NUT M8	4		
28	734532066	SOCKET BOLT M8 \times 25	4		
29	854255008	SEAL WASHER ϕ 8	4		
30	0115185	SPANNER 13MM	1		

◆ Bare engine can not be supplied

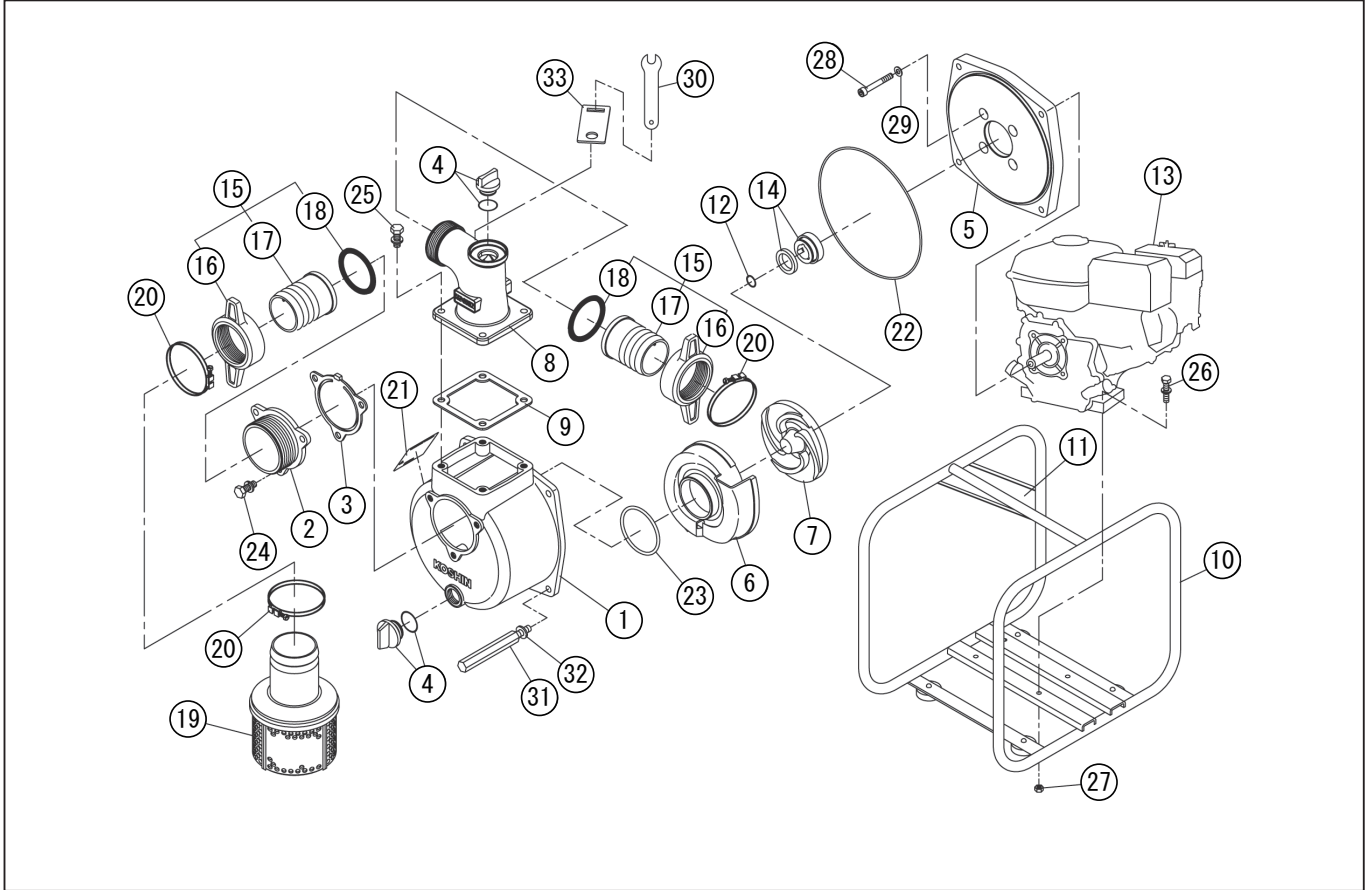

DWG No.066869602 MODELE:STH-50X FORM:STH-50X-BFH-0

No.	PARTS CODE	PARTS NAME	QTY	MATERIAL/SIZE	REMARKS
31	0115115	LONG BOLT M8X118	4		
32	843822008	SPRING WASHER	4		
33	0115230	SPANNER HOLDER	1		
	0122733	PACKING CASE	1		
	0115367	MANUAL	1		

◆ Bare engine can not be supplied